

CRAWLER CRANE  
**LC785M-8**

# TECHNICAL DATA

Metric(CE)

## Specifications

Model	LC785M-8B(F)
Crane Capacity	4.9t x 2.1m
Max. Working Radius	14.52m x 0.20t
Max.Lifting Height	16.35m (20.3m with fly jib)
Max. Reach Below Ground	-25.6m (4 falls)
Pick & Carry Capacity	2,000kg
Travel Speed	0-4.5km/h
Travel Ground Pressure	50.0kpa [0.51kgf/cm <sup>2</sup> ]
Travel Ground Pressure (with fly jib)	50.8kpa [0.52kgf/cm <sup>2</sup> ]
Engine	KOMATSU SAA4D95LE-5 / Diesel
Engine Rated Output	42.8kw/1,950rpm
Dimensions	5,020mm (L) x 2,360mm (W) x 2,795mm (H)
Tail swing	1,390mm
Machine Weight	10,250kg (10,420kg with fly jib) (Rubber Pads : +280kg)

## Dimensions

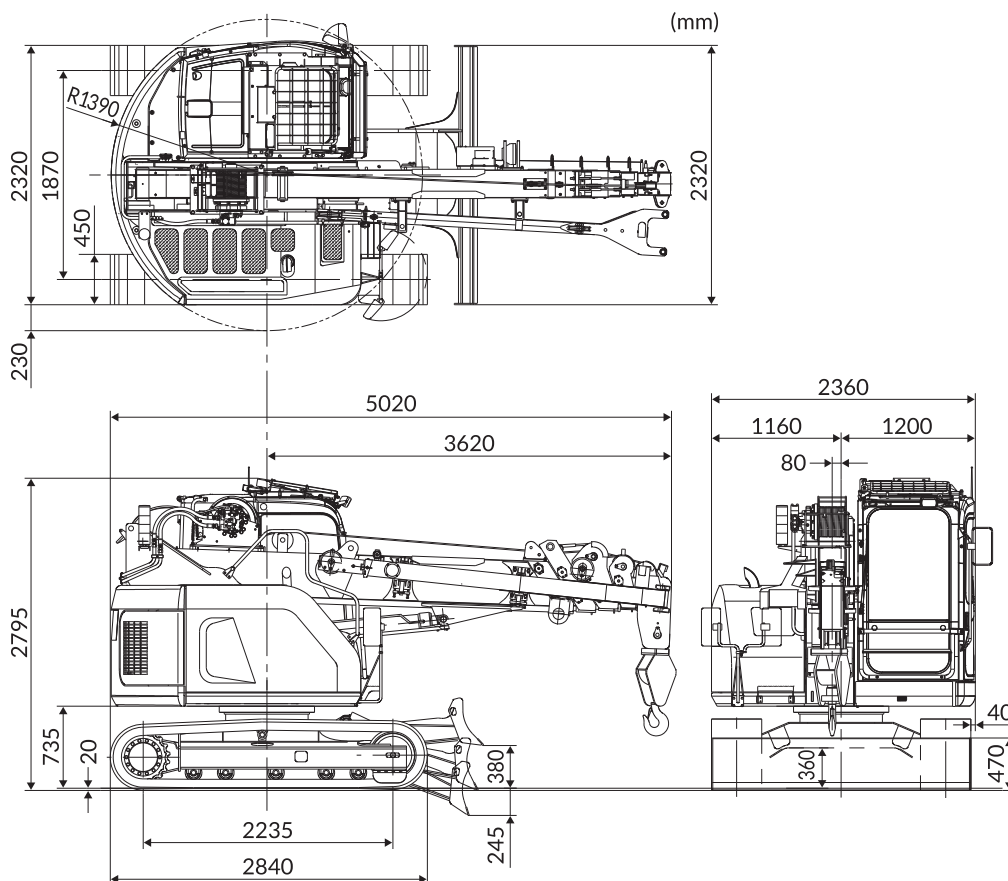

CRAWLER CRANE  
LC785M-8

# TECHNICAL DATA

Metric(CE)

## Working Range Chart

Max. Below Grade

