

Data subject to change without prior notice
Edition 04/2020 © 2020 JMG Cranes S.p.A. All rights reserved
Rev.1 - 04/2020



Electric Pick & Carry Cranes

JMG Cranes S.p.A.

Sales & Service Office

Via Bergamo, 142

26100 Cremona - Italy

t +39 0372 1786738

Production Plant

Via Sito Nuovo 14

29010 Sarmato (PC) - Italy

t +39 0523 8486

e info@jmgcranes.com

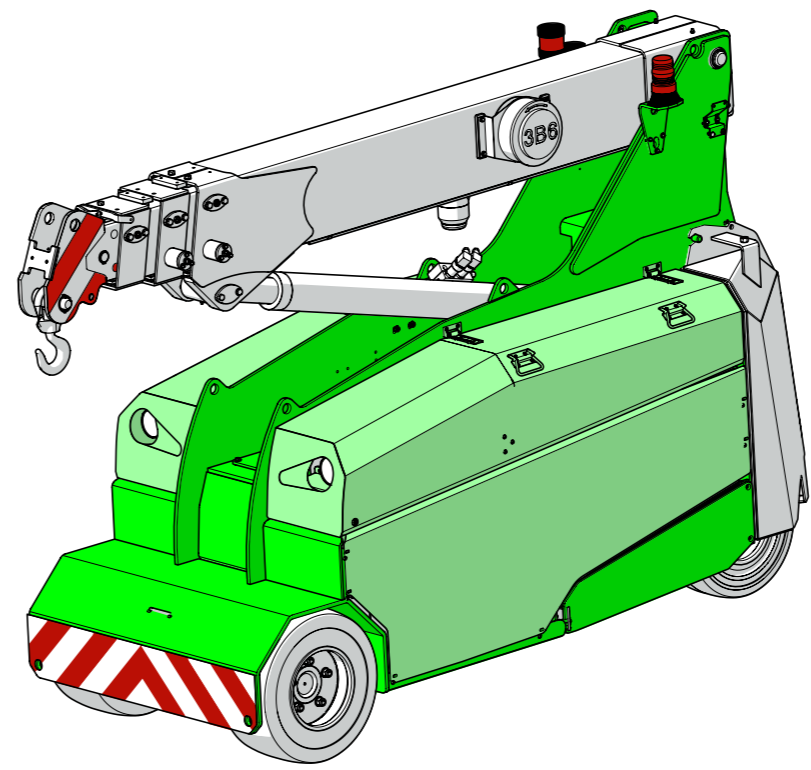

MC 32S (metric)
Max Capacity 3,200 Kg

www.jmgcranes.com



MC 32S

RADIO-REMOTE CONTROL ON DRIVING, STEERING, BOOM MOVEMENTS, WINCH AND OTHER ACCESSORIES

FRONT-WHEELS DRIVE WITH COUNTER ROTATION

REMOVABLE COUNTERWEIGHTS

HYDRAULICALLY TELESCOPING SEQUENTIAL TYPE BOOM

Options :

- HYDRAULIC WINCH
- HYDRAULIC FLY JIB
- MANUAL FLY JIB WITH EXTENSION
- NON-MARKING TIRES
- HYDRAULIC FORKS
- MAN BUCKET
- ATEX CONVERSIONS
- CUSTOMIZED PAINTING



Technical features

Max Capacity kg	3,200
Dimensions mm	2430x980x1696

Front-wheels drive. 2 electric motors AC 3 kW 48V Insulation class H	LMI. Electronic safe load indicator and tilting moment limiter
Total Kg. 3,400 Removable counterweights Kg. 700	Automatic braking system on all wheels
48 V - 500 Ah 8 working hours	Fabricated from preformed and welded quality steel plate
Front nr. 2 superelastic 200/50-10" Rear nr. 2 superelastic 16x6-8"	+60°/-15°
Rear Steering angle -90°/+90°	Motor driven pump 9 kW - 48 V AC, Insulation class H



Load charts

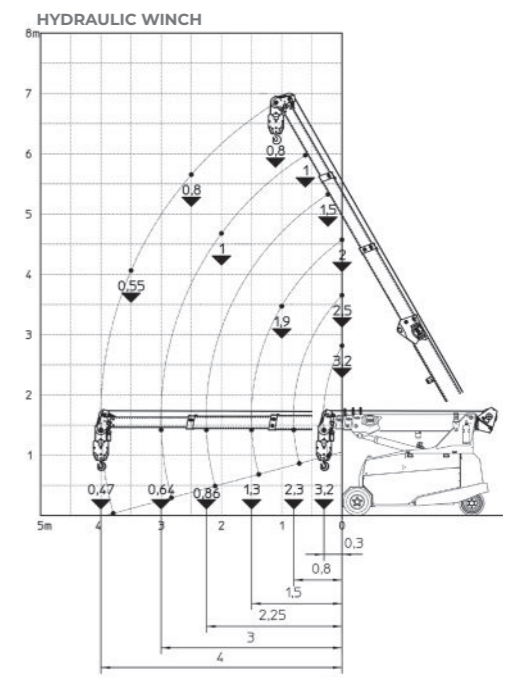
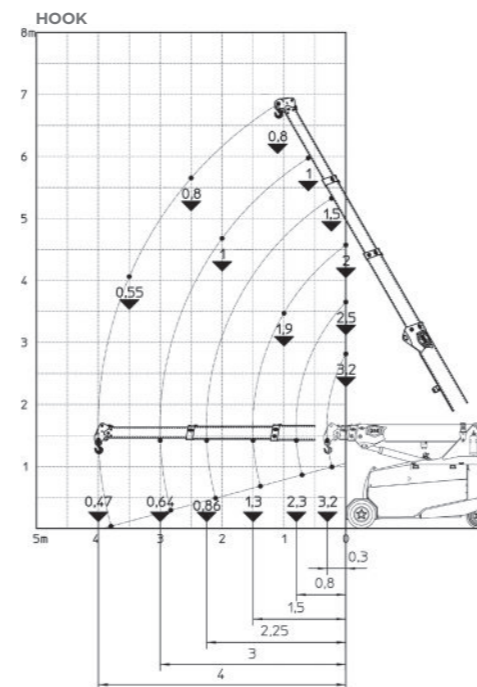

EU Standards CE

	UNI ISO 4301-2: A1
	2006/42 CE-2014/30 UE-2014/35 UE- 2000/14 e and subsequent modifications
	EN 13000:2014 ANSI/ASME B30.5-2011 and subsequent modifications



Dimensions

