



**JMG Cranes s.r.l. a socio unico**

“Società sottoposta ad attività di direzione e coordinamento di Compart Italia srl”

Sede Legale: Via Dante, 15 - 26100 CREMONA | Uffici e stabilimento: Via Sito Nuovo, 14 - 29010 Sarmato - PC - Italy  
C.F. e p.iva 05896090965 | Capitale Sociale Euro 84.000,00 i.v.  
T +39 0523 8486 | F. +39 0523 848000 | E. info@jmgcranes.com | www.jmgcranes.com

Edition 01/2016  
© 2016 JMG Cranes srl All rights reserved

# Pick&Carry Cranes



# GREENLIFTER

MAX CAPACITY 0,9 t



# GREENLIFTER<sup>0,9 t</sup>

<b>DRIVING:</b>	Manual
<b>STEERING:</b>	Rear by steering helm allowing a 90°+90° steering angle
<b>BOOM CONTROLS:</b>	Electrohydraulic controls - cable remote control power line alimented
<b>FRAME:</b>	Fabricated from preformed and welded steel plate
<b>WHEELS:</b>	Front nr. 2 polyurethane 250x60 Rear nr. 2 polyurethane 250x60
<b>OUTRIGGERS:</b>	Front outriggers complete with 250 x 60 vulkollan wheels
<b>BRAKE:</b>	Manual parking brake on front wheels
<b>BOOM:</b>	Fabricated from preformed and welded steel plate. Composed by a base fixed element, one hydraulically telescoping and complete of composable manual extensions. Boom inclindation angle +50°/-40°
<b>WEIGHT:</b>	Kg. 1.150 including Kg. 650 of dismantable counterweights. To simplify the handling the crane is dismantable in parts easily and quickly assemblable, the equipment is complete by remouvable counterweights, each one weighting Kg. 25. The crane is complete by service rubber 250 x 50 wheels
<b>OPTIONS ON REQUEST:</b>	ATEX conversions, customer painting
<b>CRANE CLASSIFICATION ACCORDING TO UNI ISO 4301-1:</b>	A3
<b>EU STANDARD CE:</b>	2006/42 CE MD - 2004/108 CE EMC - 2006/95 CE LVD - 2000/14 CE and subsequent modifications
<b>REFERENCE STANDARDS:</b>	EN 13000: 2010 UNI ISO 4301-2:2011 and subsequent modifications



ASSEMBLED



DISMOUNTABLE FOR EASY HANDLING AND TRANSPORT



DISMOUNTABLE COUNTERWEIGHTS OF 25Kg/each



HYDRAULIC BOOM WITH MANUAL EXTENSIONS

## DIMENSIONS

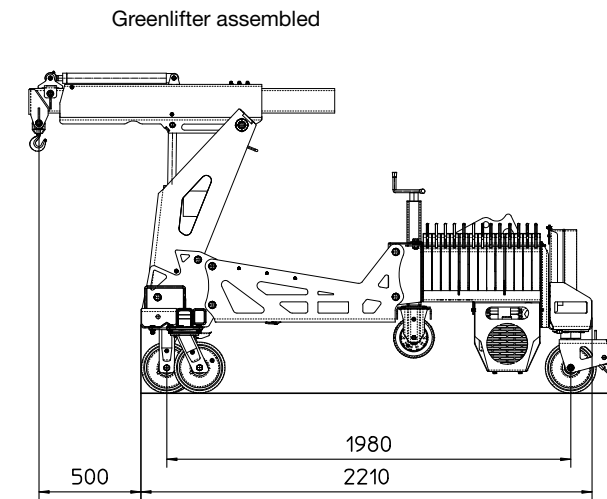

m-t

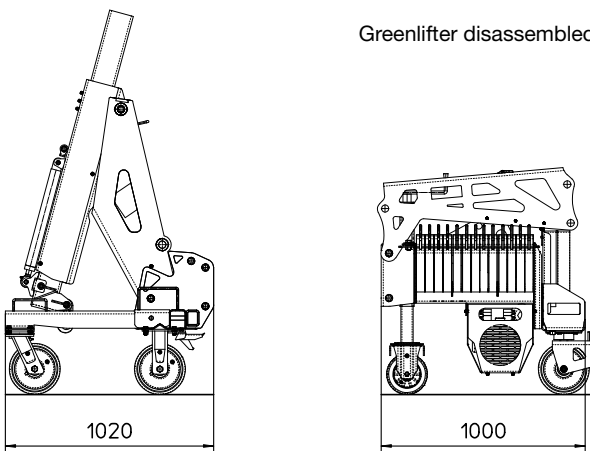
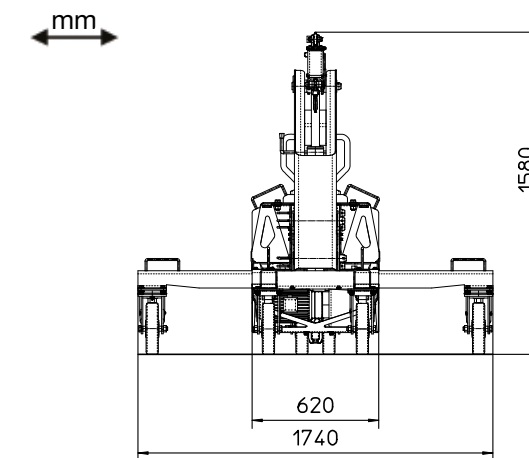

## PERFORMANCES

